

# MD 421 II

## Microphones | Dynamic Microphone

Cat. No. 000984

### General Description

The MD 421 II is one of the best known microphones in the world. Its excellent sound qualities enable it to cope with the most diverse recording conditions and broadcasting applications. The five position bass control enhances its 'all-round' qualities. Colour: black.



Cable pictured is an accessory not supplied with the microphone

### Features

- Rugged professional microphone
- Five position bass roll-off switch
- Effective feedback rejection
- Clear sound reproduction
- Easy handling due to pronounced directivity
- Delivery includes: 1 MD 421 II  
1 microphone clamp for 3/8" thread

### Recommended Accessories

- MZT 100 table stand
- MZT 441 table stand
- MZT 14 mounting bolt
- MZW 40 foam windshield
- MZW 421 foam windshield

- Cat. No. 001883
- Cat. No. 000799
- Cat. No. 001895
- Cat. No. 001794
- Cat. No. 000536

### Technical Data

|  |                  |
|--|------------------|
| Pick-up pattern .....                          | cardioid         |
| Frequency response .....                       | 30 – 17,000 Hz   |
| Sensitivity (free field, no load, 1 kHz) ..... | 2 mV/Pa ± 3 dB   |
| Nominal impedance .....                        | 200 Ω            |
| Min. terminating impedance .....               | 200 Ω            |
| Dimensions .....                               | 215 x 46 x 49 mm |
| Weight .....                                   | approx. 385 g    |

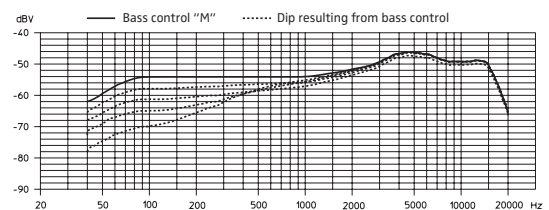
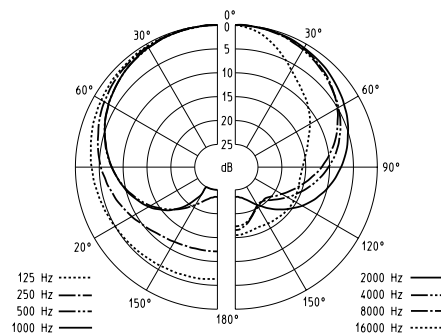

### Profile

Cardioid studio microphone, five-position bass control, frequency response 30 – 17,000 Hz, sensitivity (free field, no load) 2 mV/Pa ± 3 dB at 1 kHz, nominal impedance 200 Ω, min. terminating impedance 200 Ω, dimensions 215 x 46 x 49 mm, weight approx. 385 g.

GEBRAUCHSANLEITUNG  
INSTRUCTIONS FOR USE  
NOTICE D'EMPLOI  
ISTRUZIONI PER L'USO  
INSTRUCCIONES PARA EL USO  
GEBRUIKSAANWIJZING

**MD 421-II**

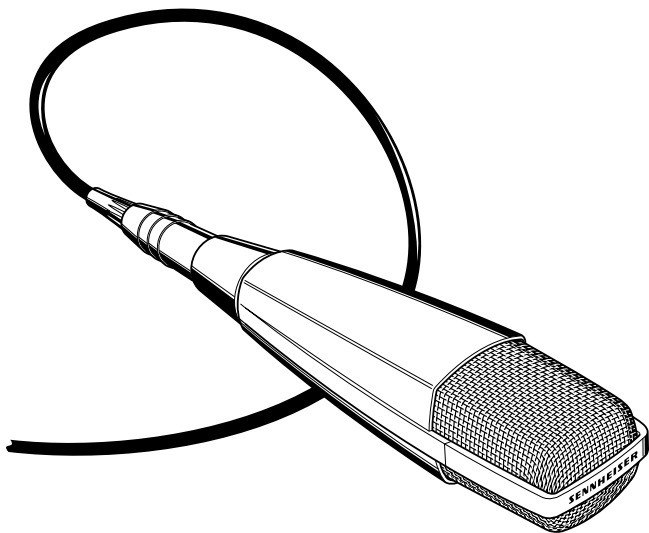

# MD 421-II

Micrófono con característica direccional cardioide. Puede ser empleado para transmisión de lenguaje hablada o de canto, así como para sonido de instrumentos en todos los campos de la técnica de transmisión de sonido

## CARACTERISTICAS

- buena amortiguación de la retroalimentación y de los ruidos corporales
- reproducción transparente del sonido
- característica acentuadamente direccional con ángulo de apertura amplio
- robusto
- reglaje de bajos con 5 etapas
- soporte para trípode enclavable

## ACCESORIOS RECOMENDADOS

**Pies de sobremesa:** MZT 441, (Art.-Nr. 00799); MZT 100 (Art.-Nr. 01883).

**Protección antiviento:** MZW 40 (Art.-Nr. 01794); MZW 421: gris (Art.-Nr. 00536); azul (Art.-Nr. 01527); rojo (Art.-Nr. 01530)

## DATOS TÉCNICOS

|   |   |
|---|---|
| Respuesta   | 30 - 17 000 Hz  |
| Funcionamiento acústico                               | receptor de gradiente de presión                                  |
| Característica direccional                            | cardioide   |
| Atenuación máxima 180°                                | 18 dB - 2 dB  |
| Factor de transmisión de campo an<br>circuito abierto | 2 mV / Pa (= -54 dBV) ± 2,5 dB                                    |
| Impedancia eléctrica                                  | 200 Ω   |
| Impedancia terminal                                   | 200 Ω   |
| Factor de interferencia magnética a 50 Hz             | < 5 μV / 5 μT   |
| Dimensiones en mm                                     | 215 x 46 x 49   |
| Peso  | unos 385 g  |
| Extensión del suministro                              | 1 Micrófono,<br>1 soporte para trípode<br>1 adaptador 3/8" → 5/8" |

Reservado el derecho a modificaciones.

# MD 421-II

Dynamic microphone with cardioid-shaped directional characteristic. Suitable for vocal transmission and miking up instruments in all fields of live sound transmission.

## ITS FEATURES

- Good feedback and handling noise rejection
- Transparent sound reproduction
- Pronounced directional characteristic
- Robust
- 5 step roll-off filter
- Lockable stand holder

## RECOMMENDED ACCESSORIES

**Desk stands:** MZT 441, (art.-no. 00799); MZT 100 (art.-no. 01883).

**Windscreens:** MZW 40 (art.-no. 01794); MZW 421: grey (art.-no. 00536); blue (art.-no. 01527); red (art.-no. 01530)

## TECHNICAL DATA

|  |  |
|--|--|
| Frequency response                       | 30 - 17,000 Hz   |
| Acoustical mode of operation             | pressure gradient transducer                             |
| Directional characteristic               | cardioid   |
| Max. rejection at 180°                   | 18 dB - 2 dB   |
| Open circuit output level                | 2 mV / Pa (= -54 dBV) ± 2,5 dB                           |
| Electrical impedance                     | 200 Ω  |
| Minimum load impedance                   | 200 Ω  |
| Insensitivity to magnetic field at 50 Hz | < 5 μV / 5 μT  |
| Dimensions in mm                         | 215 x 46 x 49  |
| Weight                                   | approx. 385 g  |
| Delivery                                 | 1 microphone,<br>1 stand holder<br>1 adaptor 3/8" → 5/8" |

Subject to alterations.

Besprechen  
Speaking into the microphone  
Utilisation  
Parlare al microfono  
Sonorizaciòn  
In de microfoon spreken

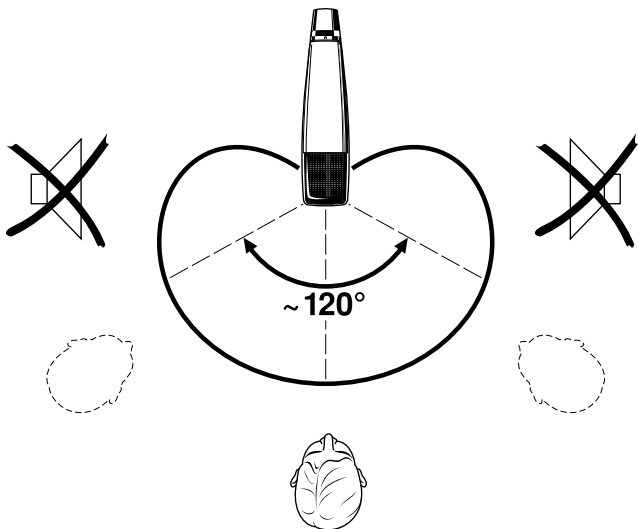
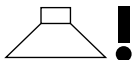

Befestigen  
Mounting  
Fixation  
Fissaggio  
Fijación  
Bevestigingen

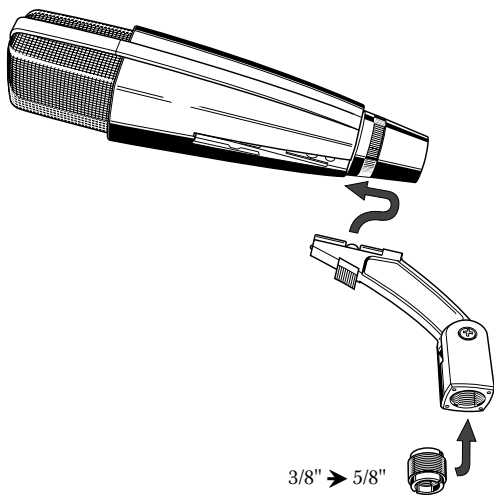

Frequenzkurve  
 Frequency response  
 Réponse en fréquence  
 Risposte in frequenza  
 Respuesta en frecuencia  
 Frequentiekromme

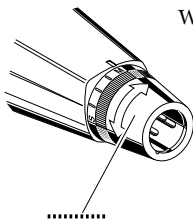

Wirkung des Baßeinstellers  
 Effect of the roll-off filter  
 Effect du filtre roll-off  
 Effetto del filtro roll-off  
 Efecto del filtro roll-off  
 Werking van de basinstelling

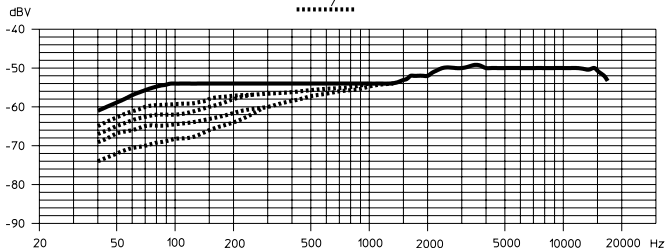

Anschluß  
 Connecting the microphone  
 Connexion  
 Collegamento  
 Conexiòn  
 Aansluiting

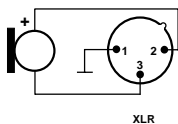

XLR

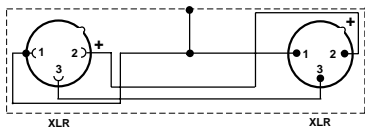

XLR

XLR

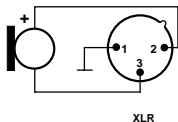

XLR

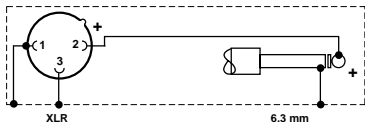

XLR

6,3 mm

Richtdiagramm  
 Polar diagram  
 Diagramme de la directivité  
 Diagramma polare  
 Diagrama de la directividad  
 Richtdiagram

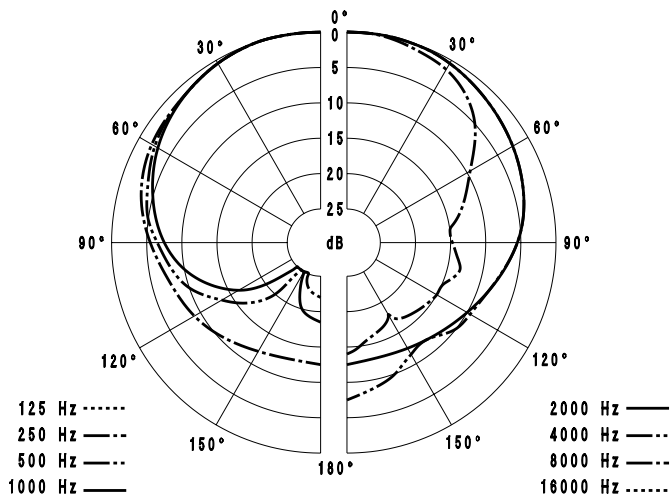





Sennheiser electronic GmbH & Co. KG  
D-30900 Wedemark  
Printed in Germany

Telefon 05130/600-0  
Telefax 05130/600-300  
Publ. 01/98 54558/A03

 **SENNHEISER**

Type: MD 421-II

No.: 318566

Date: 1359

Sign: MS

